

M50805-XXXP,FP/M50806-XXXP,FP

6249826 MITSUBISHI ELEK (LINEAR)

80C 09449 D T-77-13

SINGLE-CHIP CMOS SPEECH SYNTHESIZER

DESCRIPTION

The M50805-XXXP, FP/M50806-XXXP, FP, are single chip C-MOS PARCOR speech synthesizers and contain a speech data, ROM, a clock generator, a D-A converter and a speaker drive circuit.

The differences among the M50805-XXXP, FP/M50806-XXXP, FP are shown in the following table. The M50805-XXXP will be discussed below.

Type	Operating supply voltage range	Outline
M50805-XXXP	V _{CC} =3.0~5.5V	22 pin, plastic DIP
M50805-XXXFP	V _{CC} =3.0~5.5V	24 pin, plastic DIP
M50806-XXXP	V _{CC} =2.1~3.5V	22 pin, plastic DIP
M50806-XXXFP	V _{CC} =2.1~3.5V	24 pin, plastic DIP

FEATURES

- Speech synthesis time 5 seconds (max)
- Number of words selection 8 (max)
- Melody generation possible 20 seconds (max)
- Automatic power down function
- Built-in speaker drive circuit
- Built-in D-A converter ±6 bits PWM method
- Low power dissipation due to C-MOS process
 Supply current in operating . . . 2mA (max)
 in standby 10µA (max)
- Built-in clock generator

APPLICATION

- Home appliances
- Toys
- Watches, cameras, desk-top calculators
- Alarms

PIN CONFIGURATION (TOP VIEW)

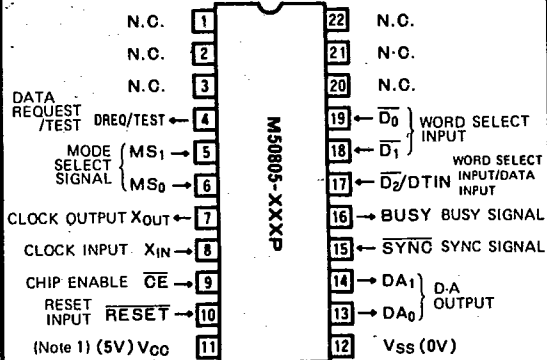

Outline 22P4 (M50805-XXXP)
(M50806-XXXP)

Note 1. For M50806-XXXP, FP the value is 3V.

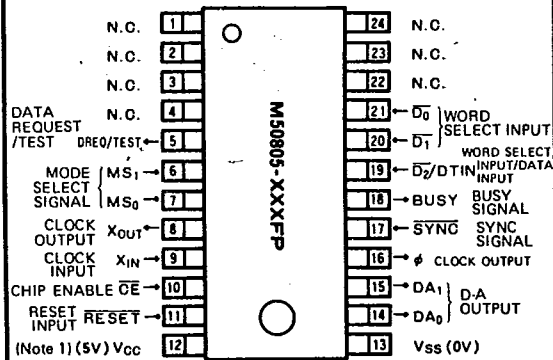

Outline 24P2W (M50805-XXXFP)
(M50806-XXXFP)

NC: NO CONNECTION

M50805-XXXP,FP/M50806-XXXP,FP

6249826 MITSUBISHI ELEK (LINEAR)

80C 09450

D 7-77-13

SINGLE-CHIP CMOS SPEECH SYNTHESIZER

BLOCK DIAGRAM

M50805-XXXP/M50806-XXXP

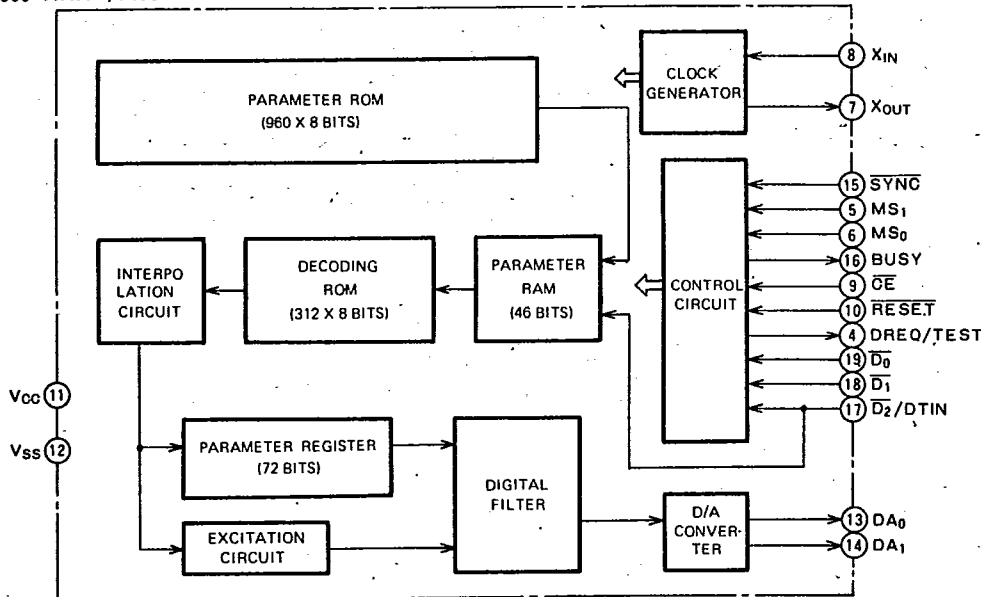

M50805-XXXFP/M50806-XXXFP

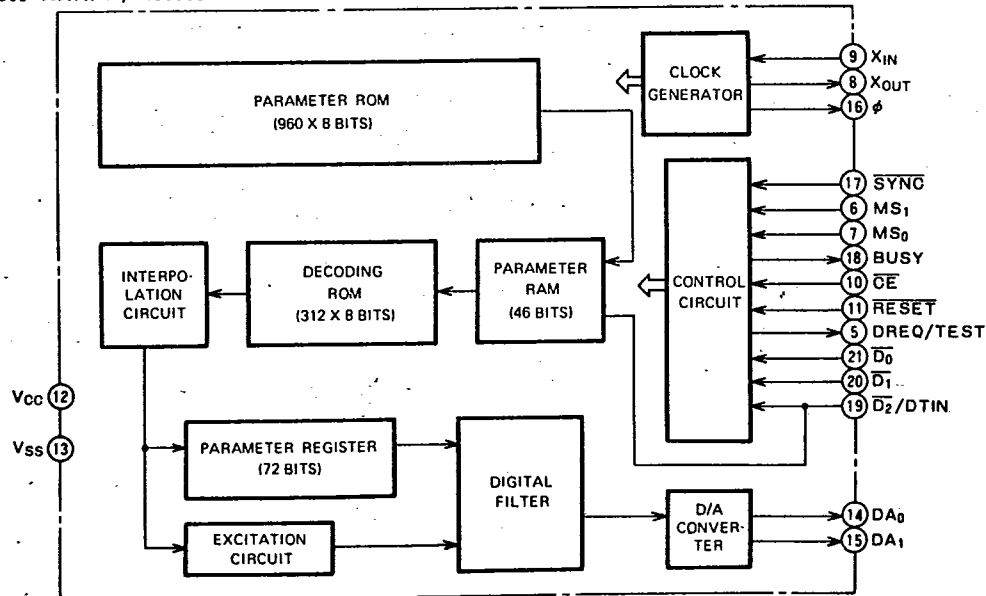

M50805-XXXP,FP/M50806-XXXP,FP

6249826 MITSUBISHI ELEK (LINEAR)

80C 09451

D 7-77-13

SINGLE-CHIP CMOS SPEECH SYNTHESIZER

PIN DESCRIPTION

Pin	Name	Input or output	Pull-up resistor Yes/No	Function
V _{CC}	Supply voltage input	Input		Positive voltage supply pin
V _{SS}	Supply voltage input	Input		Ground pin
MS ₀ , MS ₁	Mode select signal	Input		Depending on the MS ₀ , MS ₁ signal there are 4 modes that may be selected; key input mode, microcomputer control mode, external memory mode and test mode.
$\overline{D_0}$, $\overline{D_1}$	Word select input	Input	Option	When in the key input mode, voice generation begins whenever $\overline{D_0}$, $\overline{D_1}$, or $\overline{D_2}$ becomes low-state. A maximum of 7 words may be designated.
$\overline{D_2}$ /DTIN	Word select input/data input			When in the microcomputer control mode, a maximum of addresses for 8 words may be designated with $\overline{D_0}$, $\overline{D_1}$, $\overline{D_2}$. When in the external memory mode, speech parameters are inputted via DTIN.
\overline{SYNC}	Synchronous signal	Input	Option	When in microcomputer control mode, the SYNC signal initiates $\overline{D_0} \sim \overline{D_2}$ address read, starting voice generation. When in external memory mode, voice generation is started.
BUSY	Busy signal	Output		Output signal pin for indicating that voice generation is in progress.
\overline{CE}	Chip enable	Input		When the pin CE is high-level, the internal power supply is off and, when low-level, the internal power supply is on.
DA ₀ , DA ₁	D-A output	Output		±6 bit PWM output
X _{IN}	Clock input	Input		These pins are for connection to a ceramic resonator for the clock generator, or they can be connected to an external resistance R for CR clock generation. When using an external clock input, connect the oscillator source to X _{IN} pin and open X _{OUT} .
X _{OUT}	Clock output	Output		
DREQ/TEST	Data request/test	Output		This is the data request signal output pin for external memory. During test mode this is the test output pin.
\overline{RESET}	Reset input	Input	Yes	When power input is first applied the internal registers are cleared and D-A output is muted.
ϕ (M50805-XXFP) ϕ (M50806-XXFP)	Clock output	Output		160kHz clock output pin

BASIC FUNCTION BLOCKS

Parameter ROM

A 960 word x 8 bit constructed mask ROM, it stores speech parameters.

There is enough memory storage for about 5 seconds of voice and sound effects and in the case of melody about 20 seconds. Voice, sound effects and melody can be stored together. In this case each length of time can be calculated by the following diagram.

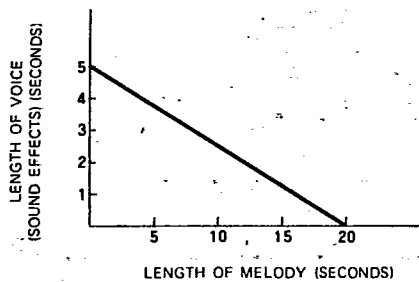

Parameter RAM

This has 46 bit capacity for temporary storage of one frame of speech parameters (amplitude, pitch, and K-parameters)

Decoding ROM

Decodes the speech parameters that had been coded by the parameter RAM. It has 312 word x 8 bit construction.

Interpolation Circuit

Provides a linear interpolation of K-parameters, pitch and amplitude every 2.5ms.

Excitation Circuit

Having both a pulse generator and a white noise generator, it generates voiced and unvoiced sounds.

Parameter Register

A register used to temporarily store data which has been linearly interpolated.

Digital Filter

It is a 12 bit 8 stage lattice digital filter.

M50805-XXXP,FP/M50806-XXXP,FP

6249826 MITSUBISHI ELEK (LINEAR)

80C 09452

D 7-77-13

SINGLE-CHIP CMOS SPEECH SYNTHESIZER

Control Circuit

According to the external input, it controls LSI operation.

Mode Select Signal MS₀, MS₁

Depending on MS₀, and MS₁, four kinds of mode may be selected as shown in the following diagram.

Mode	MS ₀	MS ₁	Use
Key input mode	H	L	Suitable for use when not editing phrases is necessary.
Microcomputer control mode	L	L	Suitable for use when the editing of phrases is necessary.
External memory mode	L	H	For use when an external memory such as EPROM and RAM is used.
Test mode	H	H	For test purposes

(1) Key Input Mode

Pin conditions

- Mode select signal pins MS₀ is connected to V_{CC} and MS₁ to V_{SS}.
- SYNC pin connects to V_{CC}.
- CE pin connects to V_{SS}.
- D₀ ~ D₂ pins when any of these pins is low-level, speech generation begins automatically. Seven kinds of phases may be selected.

Input/output timing chart

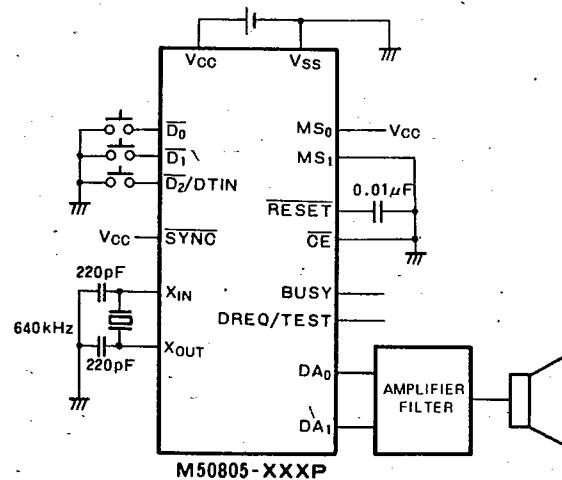
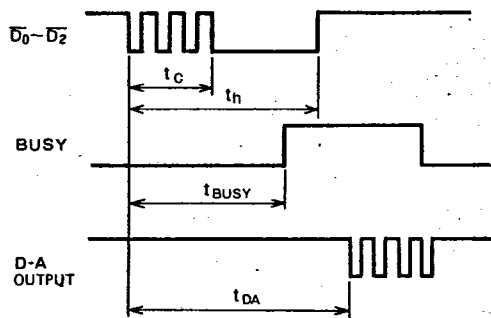

Symbol	Parameter	Min	Typ	Max	Unit
t _C	Key debounce protection time	5			ms
t _h	Data hold time	50			ms
t _{BUSY}	BUSY output delay	50			ms
t _{DA}	Speech output delay	100			ms

M50805-XXXP,FP/M50806-XXXP,FP

6249826 MITSUBISHI ELEK (LINEAR)

80C 09453

D 7-77-13

SINGLE-CHIP CMOS SPEECH SYNTHESIZER

(2) Microcomputer Control Mode

Pin conditions

- Mode select signal pins . . . Both MS₀ and MS₁ are connected to V_{SS}.
- SYNC signal When it becomes low-level for 18μs, data of both D₀ ~ D₂ is latched and speech generation begins.
- D₀ ~ D₂ pins Eight kinds of phrases may be selected.

Input output Timing chart

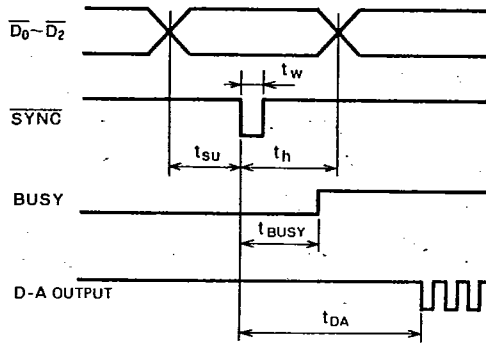

Symbol	Parameter	Min	Typ	Max	Unit
t _{su}	Data setup time	0			μs
t _h	Data hold time	25			μs
t _{w(SYNC)}	SYNC pulse width	18			μs
t _{BUSY}	BUSY output delay	12		25	μs
t _{DA}	Speech output delay	40		60	ms

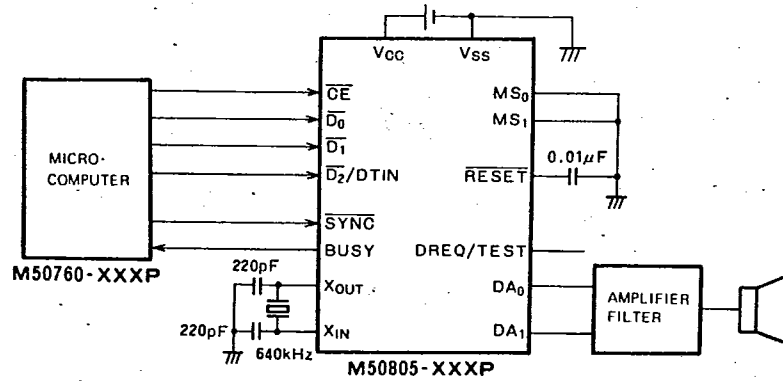

M50805-XXXP,FP/M50806-XXXP,FP

SINGLE-CHIP CMOS SPEECH SYNTHESIZER

(3) External Memory Mode

Pin conditions

- Mode select signal pins . . . MS₀ is connected to V_{SS} and MS₁ to V_{CC}.
- SYNC pin When it becomes low-level for more than 18μs, speech generation begins.
- D₂/DTIN pin Receives serial data from external ROM.
- DREQ/TEST pin Outputs the read pulse for external ROM data
- D₀, D₁ pins Connected to V_{CC}.

Input timing chart

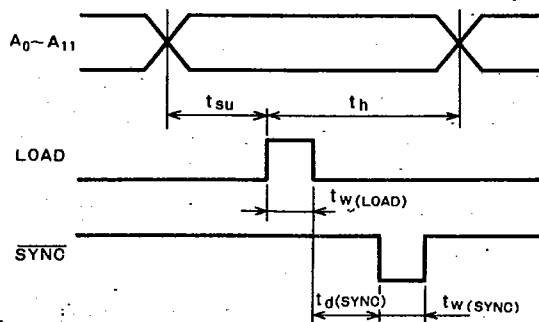

Timing Requirement

Symbol	Parameter	Min	Typ	Max	Unit
t _{su}	Data set up time	1			μs
t _h	Data hold time	2			μs
t _{w(Load)}	LOAD pulse width	1			μs
t _{d(SYNC)}	SYNC delay time	0			μs
t _{w(SYNC)}	SYNC pulse width	18			μs

Application Example in the External Memory Mode

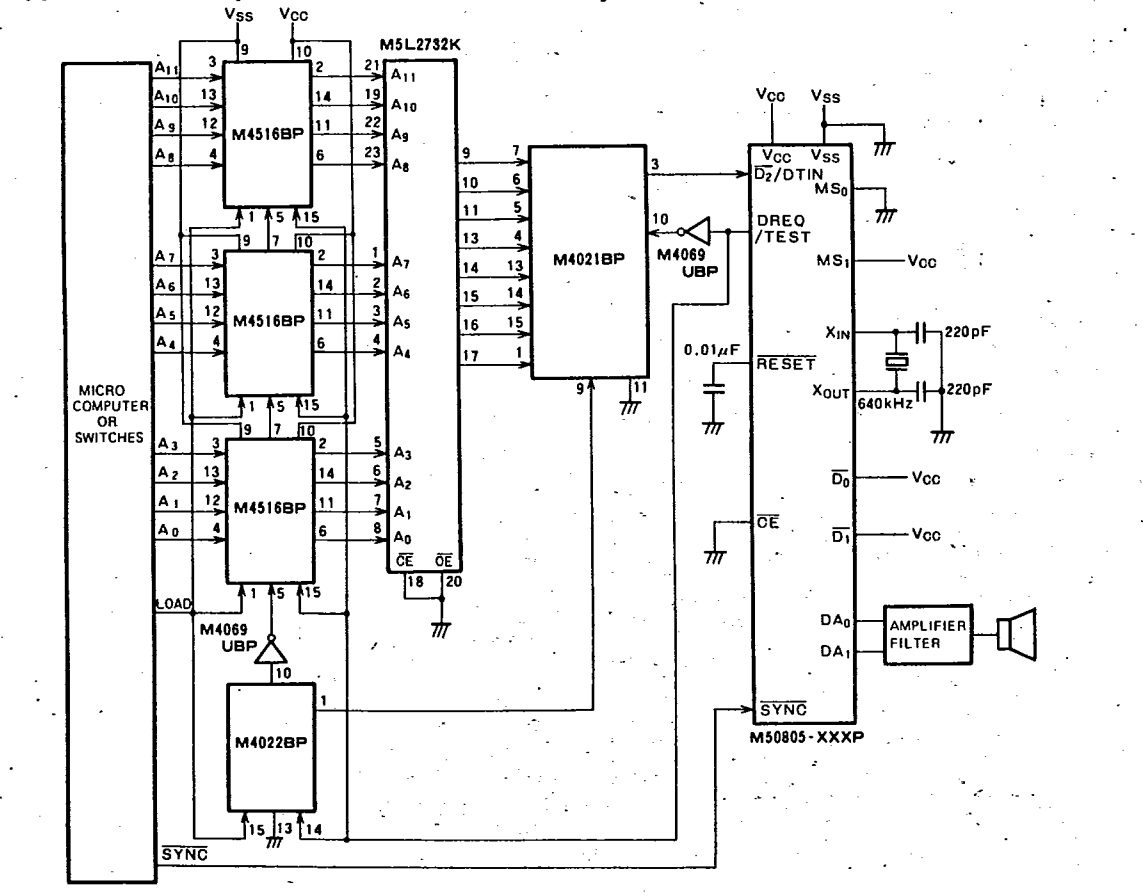

M50805-XXXP,FP/M50806-XXXP,FP

6249826 MITSUBISHI ELEK (LINEAR)

80C 09455 D 7-77-13

SINGLE-CHIP CMOS SPEECH SYNTHESIZER

Input/Output Pins

Chip enable pin (CE)

CE	Mode	Function
H	All modes	When input is high-level, internal power supply is turned off and device enters standby condition. In standby, both DA ₀ and DA ₁ become high-level.
L	Microcomputer control mode/ external memory mode	When input is low-level, internal power supply is turned on. At this time a reset signal is automatically generated and device enters power-on-initialization sequence.
	Key input mode	The internal power supply is turned on after receiving key input. At this time a reset signal is automatically generated and device enters power-on-initialization sequence. After voice generation has ceased, automatic power down circuit operates and device enters key input waiting state. While in the waiting state, BUSY becomes low-level and both DA ₀ and DA ₁ become high-level.

D-A Output Circuit (DA₀, DA₁)

D-A output is PWM (pulse width modulation) and outputted from pin DA₀ when positive and pin DA₁ when negative.

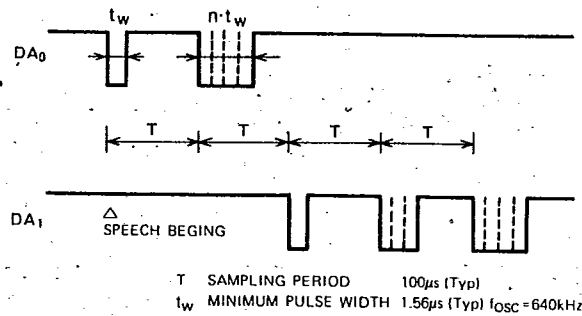

Reset Pin (RESET)

The reset pin must become low-level in more than 5ms after power has been applied and the supply voltage has reached 90%.

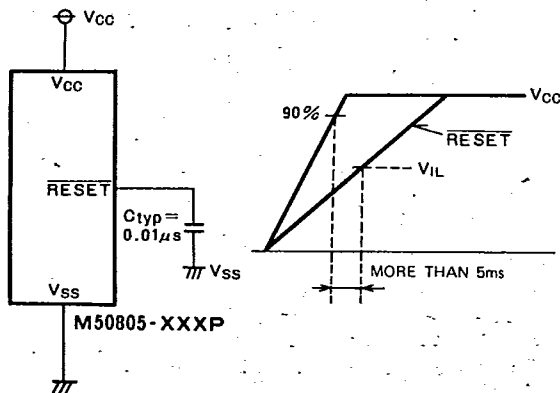

Busy Pin (BUSY)

Mode	BUSY output
Microcomputer control mode External memory mode	The output of this pin becomes high-level during each of the following. Voice generation, power-on-initialization and standby. It is necessary to ensure that the BUSY signal is low-level prior to generating the voice start signal. If the BUSY signal is high-level, the voice generation start signal has no effect.
Key input mode	The output of this pin becomes high-level during voice generation and low-level during power-on-initialization and while in the waiting condition. It is necessary to ensure that the BUSY signal is low-level prior to generating the voice start signal. If the BUSY signal is high-state, the voice start signal has no effect.

M50805-XXXP,FP/M50806-XXXP,FP

6249826 MITSUBISHI ELEK (LINEAR)

80C 09456

D T-77-13

SINGLE-CHIP CMOS SPEECH SYNTHESIZER

Clock Generator

The device contains a clock generator which can generate a clock signal when either a ceramic resonator or resistor is connected externally between the clock output and input pins (X_{IN} , X_{OUT}).

When a clock signal from an external source is being used, connect the source of the clock oscillator to pin X_{IN} and open pin X_{OUT} . Designate whether or not a ceramic resonator or a resistor will be used in the clock oscillator circuit as a mask option.

Circuit examples are given below.

Externally connected ceramic resonator circuit

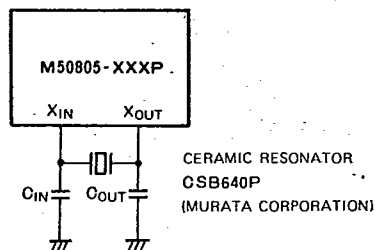

	M50805-XXXP/FP	M50806-XXXP/FP
C_{IN}	220pF	100pF
C_{OUT}	220pF	100pF

Externally connected resistor

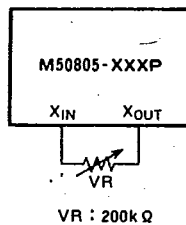

External clock input circuit

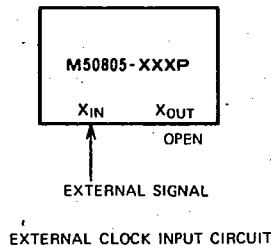

MASK OPTION

The following mask options are available, specifiable at the time of ordering maskings.

- (1) Continuous/single voice generation selecting specification

Continuous voice generation:

Voice generation continues as long as $\overline{D_0} \sim \overline{D_2}$ is kept continuously low-level in the key input mode or \overline{SYNC} is kept continuously low-level in the microcomputer control mode.

Single voice generation:

Voice generation occurs only once when the above conditions are met. To generate the voice again it is necessary to return either the $\overline{D_0} \sim \overline{D_2}$ or the \overline{SYNC} to high-level one time and then to low-level again.

- (2) Specifications concerning the inclusion or exclusion of pull-up resistors for the word select input pins $\overline{D_0}$, $\overline{D_1}$, $\overline{D_2}$, and the synchronous signal \overline{SYNC} .
- (3) Specifications concerning whether or not a ceramic resonator or a resistor will be used in the oscillator circuit.

M50805-XXXP,FP/M50806-XXXP,FP

6249826 MITSUBISHI ELEK (LINEAR)

80C 09457 D 7-77-13

SINGLE-CHIP CMOS SPEECH SYNTHESIZER

ELECTRICAL CHARACTERISTICS OF THE M50805-XXXP/M50805-XXFP

ABSOLUTE MAXIMUM RATINGS

Symbol	Parameter	Conditions	Ratings	Unit
V _{CC}	Supply voltage	With respect to the V _{SS} Pin	-0.3~7	V
V _I	Input voltage		-0.3~7	V
P _d	Maximum power dissipation	T _a = 25°C	150	mW
T _{opr}	Operating temperature		-10~70	°C
T _{stg}	Storage temperature		-40~125	°C

RECOMMENDED OPERATING CONDITIONS (T_a = -10~70°C, unless otherwise noted)

Symbol	Parameter	Limits			Unit
		Min	Typ	Max	
V _{CC}	Supply voltage	3	5	5.5	V
V _{SS}	Supply voltage	0	0	0	V
f _{osc}	Oscillation frequency		640		kHz

ELECTRICAL CHARACTERISTICS (T_a = -10~70°C, f_{osc} = 640 ± 20kHz, V_{CC} = 3~5.5V, unless otherwise noted)

Symbol	Parameter	Test conditions	Limits			Unit
			Min	Typ	Max	
V _{OH}	High-level output voltage BUSY, DREQ/TEST	I _{OH} = 0.1mA	V _{CC} - 0.8			V
V _{OL}	Low-level output voltage BUSY, DREQ/TEST	I _{OL} = 0.4mA			0.8	V
I _{OH}	High-level output current DA ₀ , DA ₁	V _{OH} = V _{CC} - 0.4V	1			mA
I _{OL}	Low-level output current DA ₀ , DA ₁	V _{OL} = 0.4V	1.6			mA
I _{DA}	D/A output current	Resistor between DA ₀ and DA ₁ 10Ω at V _{CC} = 5V		45		mA
I _{OC}	Supply current (in operation)	Unloaded input/output			2	mA
I _{SC}	Supply current (standby)	Unloaded input/output			10	μA
I _{IL}	Input leak current	V _I = 0 ~ V _{CC}			± 1	μA
R _I	Pull-up resistor $\overline{D_0} - \overline{D_2}$	V _I = V _{SS} , V _{CC} = 5V		180		kΩ
R _I	Pull-up resistor SYNC	V _I = V _{SS} , V _{CC} = 5V		300		kΩ
V _{IH}	High-level input voltage	V _{CC} = 4 ~ 5.5V	V _{CC} - 1		V _{CC}	V
V _{IL}	Low-level input voltage	V _{CC} = 4 ~ 5.5V	0		1	V

M50805-XXXP,FP/M50806-XXXP,FP

6249826 MITSUBISHI ELEK (LINEAR)

80C 09458

D 7-77-13

SINGLE-CHIP CMOS SPEECH SYNTHESIZER

ELECTRICAL CHARACTERISTICS OF THE M50806-XXXP/M50806-XXXFP

ABSOLUTE MAXIMUM RATINGS

Symbol	Parameter	Conditions	Limits	Unit
V _{CC}	Supply voltage	With respect to the V _{SS} pin	-0.3~7	V
V _I	Input voltage		-0.3~7	V
P _d	Maximum power dissipation	T _a = 25°C	150	mW
T _{opr}	Operating temperature		-10~70	°C
T _{stg}	Storage temperature		-40~125	°C

RECOMMENDED OPERATING CONDITIONS (T_a = -10~70°C, unless otherwise noted)

Symbol	Parameter	Limits			Unit
		Min	Typ	Max	
V _{CC}	Supply voltage	2.1	3	3.5	V
V _{SS}	Supply voltage	0	0	0	V
f _{osc}	Oscillation frequency		640		KHz

ELECTRICAL CHARACTERISTICS (T_a = -10~70°C, f_{osc} = 640 ± 20kHz, V_{CC} = 2.1~3.5V, unless otherwise noted)

Symbol	Parameter	Test conditions	Limits			Unit
			Min	Typ	Max	
V _{OH}	High-level output voltage BUSY, DREQ/TEST	I _{OH} = 0.1mA	V _{CC} - 0.8			V
V _{OL}	Low-level output voltage BUSY, DREQ/TEST	I _{OL} = 0.4mA			0.8	V
I _{OH}	High-level output current DA ₀ , DA ₁	V _{OH} = V _{CC} - 0.4V	0.5			mA
I _{OL}	Low-level output current DA ₀ , DA ₁	V _{OL} = 0.4V	0.8			mA
I _{DA}	D/A output current	Resistor between DA ₀ and DA ₁ 10Ω at V _{CC} = 3V		20		mA
I _{OC}	Supply current (in operation)	Unloaded input/output			1	mA
I _{SC}	Supply current (standby)	Unloaded input/output			10	μA
I _{IL}	Input leak current	V _I = 0 ~ V _{CC}			± 1	μA
R _I	Pull-up resistor D ₀ ~D ₂	V _I = V _{SS} , V _{CC} = 3V		320		kΩ
R _I	Pull-up resistor SYNC	V _I = V _{SS} , V _{CC} = 3V		560		kΩ
V _{IH}	High-level input voltage		3/4 V _{CC}		V _{CC}	V
V _{IL}	Low-level input voltage		0		1/4 V _{CC}	V

M50805-XXXP,FP/M50806-XXXP,FP

6249826 MITSUBISHI ELEK (LINEAR)

80C 09459 D 7-77-13

SINGLE-CHIP CMOS SPEECH SYNTHESIZER

APPLICATION CIRCUIT EXAMPLES
Speaker Drive Circuit

a) Direct drive

Maximum output power
=10mW typ ($V_{CC}=5V$)

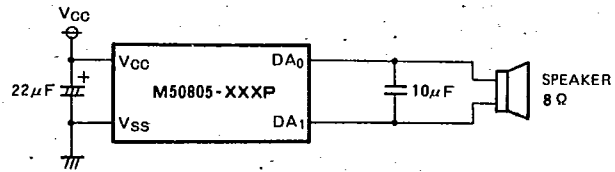

b) Using an amplifier

• Maximum output power
=60mW typ ($V_{CC}=5V$)

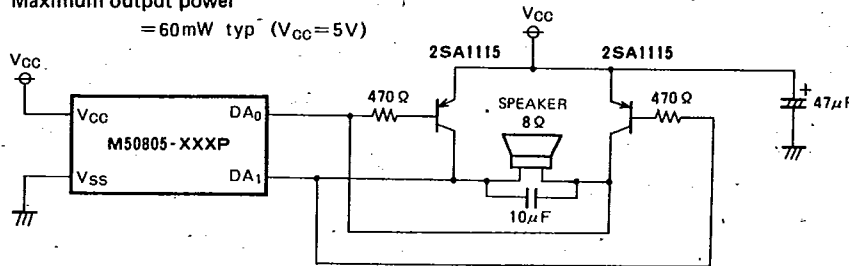

• Maximum output power
= 500mW typ ($V_{CC}=5V$)
With volume control

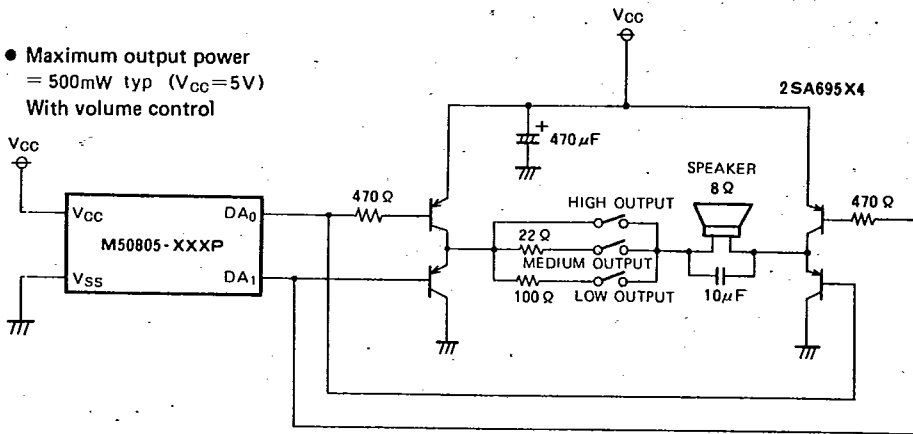

c) Filter amplifier circuit

Operational amplifier used as a filter amplifier circuit
Maximum output power = 200mW typ. ($V_{CC}=5V$)

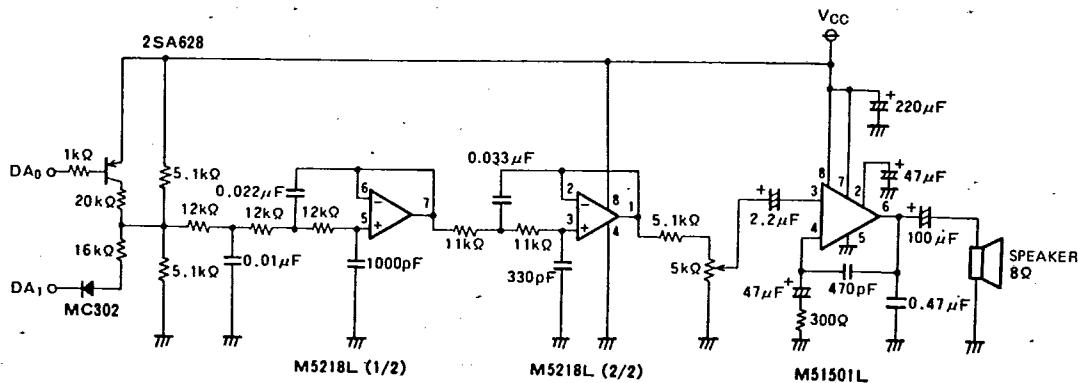

M50805-XXXP,FP/M50806-XXXP,FP

6249826 MITSUBISHI ELEK (LINEAR)

80C 09460

D 7-77-13

SINGLE-CHIP CMOS SPEECH SYNTHESIZER

METHOD OF ORDERING SPEECH ANALYSIS AND MASK ROM

Steps taken in ordering

(1) Decisions concerning specifications

Decide the specifications concerning the content of the speech, the language, the speaker, etc.

(2) Ordering

When ordering, ensure that the necessary information has been entered in both the speech Analysis Request Form and Speech List. Be sure to also include the musical score if a melody is necessary.

(3) Recording

A recording of the original speech is made in a studio using an experienced narrator. Attendance is permitted for either confirmation or giving speech instructions.

(4) Analysis

Speech parameters of the voice are analyzed through use of a voice analysis system centered on a MELCOM 70/40 mini-computer in the Mitsubishi Speech Center. The data is written on a EPROM, and along with the Analysis Approval Form and Masking Approval Form is forwarded to the customer.

(5) Sound evaluation

The delivered EPROM is inserted in either Mitsubishi's voice evaluation board or a similar device and the quality of the synthesized speech is confirmed. If the quality is found to be acceptable, the Analysis Approval Form and the Masking Approval Form are to be signed and returned to Mitsubishi.

(6) Mask production

A MASK ROM is produced from the EPROM data. An ES sample for the confirmation of electrical characteristics is sent along with an ES Approval Form to the customer.

(7) Sample evaluation

If results of ES sample evaluation prove to be acceptable the ES Approval Form is to be signed and returned to Mitsubishi.

(8) CS sample production

This is a sample having the same characteristics as the mass produced device.

(9) Mass production

After production of the CS sample mass production is begun.

M50805-XXXP,FP/M50806-XXXP,FP

6249826 MITSUBISHI ELEK (LINEAR)

80C 09461

D 7-77-13

SINGLE-CHIP CMOS SPEECH SYNTHESIZER

ORDERING FLOW CHART

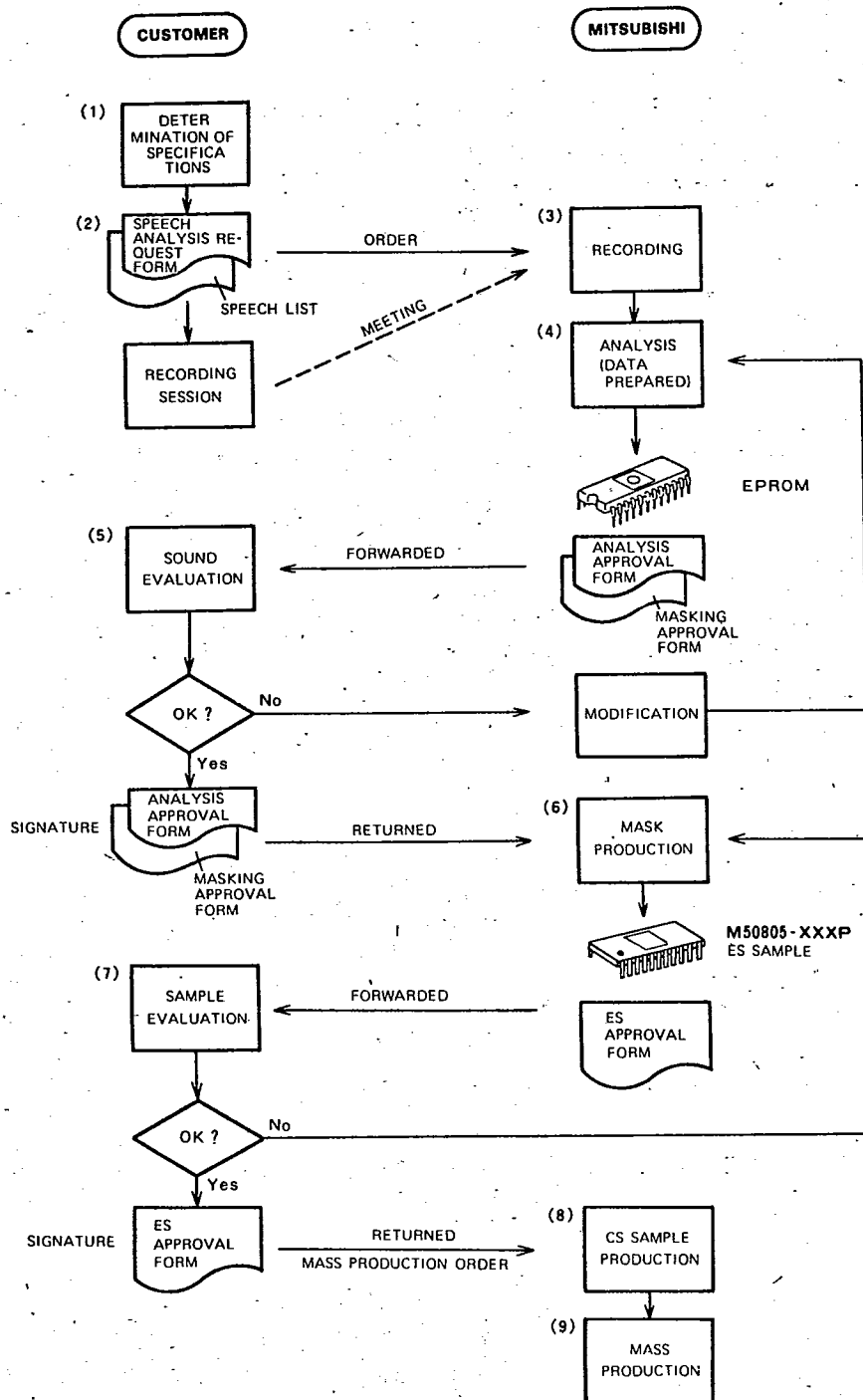

M50805-XXXP,FP/M50806-XXXP,FP

SINGLE-CHIP CMOS SPEECH SYNTHESIZER

MITSUBISHI SPEECH SYNTHESIZER LSI

M50805-XXXP, FP

M50806-XXXP, FP

SPEECH ANALYSIS REQUEST FORM

Customer		Signature	
Company name _____		Prepared	
Company address _____	Tel _____	Approved	
Company contact _____	Date _____		

1. Specifications

Recording

(necessary/unnecessary)

_____ Language _____ Sex _____

Analysis

(necessary/unnecessary)

_____ Length of speech _____ seconds
 _____ Length of melody _____ seconds
 _____ Voice evaluation board (necessary/unnecessary)

Mask

(necessary/unnecessary)

2. Schedule

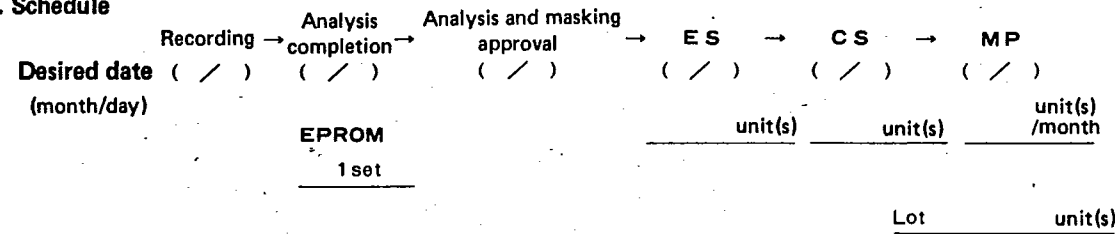

Mitsubishi Entry Column

Parameter	Type	Order number	Amount	Cost	Order date	Completion date	Transfer of money
Recording	VOICE-SOFT	00-38-					
Analysis	VOICE-SOFT	00-38-					
Voice evaluation board	VOICE-SOFT	00-38-					
Mask	VOICE-MASK						

Notes



M50805-XXXP,FP/M50806-XXXP,FP

6249826 MITSUBISHI ELEK (LINEAR)

80C 09463

D 7-77-13

SINGLE-CHIP CMOS SPEECH SYNTHESIZER

Mask ROM number

M50805-XXXP, FP SPEECH LIST
M50806-XXXP, FP

No.	Address			Speech content	Notes
	D ₂	D ₁	D ₀		
1	H	H	L		
2	H	L	H		
3	H	L	L		
4	L	H	H		
5	L	H	L		
6	L	L	H		
7	L	L	L		
8	H	H	H		